



We lift you!

X2 telescopic columns are used wherever robust and reliable guiding systems are needed to lift medical, ergonomical or industrial equipment.

Our lifting columns are available with square, rectangular and acicular tubes from 2 sections up to 6 sections.

You can find our standard product range on our website, but if you can't find any that fulfils your needs then we can make a customized solution for you, in fact most of our supplied lifting columns are customized.

Specifications:				
Column	Max Force	Max Speed	Max Stroke	Max Offset
A-type	6000 N	120 mm/s	3000 mm	2000 Nm
B-type	6000 N	120 mm/s	2500 mm	1500 Nm
E-type	2000 N	30 mm/s	700 mm	750 Nm
F-type	3000 N	30 mm/s	700 mm	1000 Nm
G-type	3000 N	30 mm/s	1500 mm	1500 Nm
X-type	10 000 N	120 mm/s	3000 mm	3000 Nm

A-type
Available with 2-, 3-, 4-, 5- and 6-sections

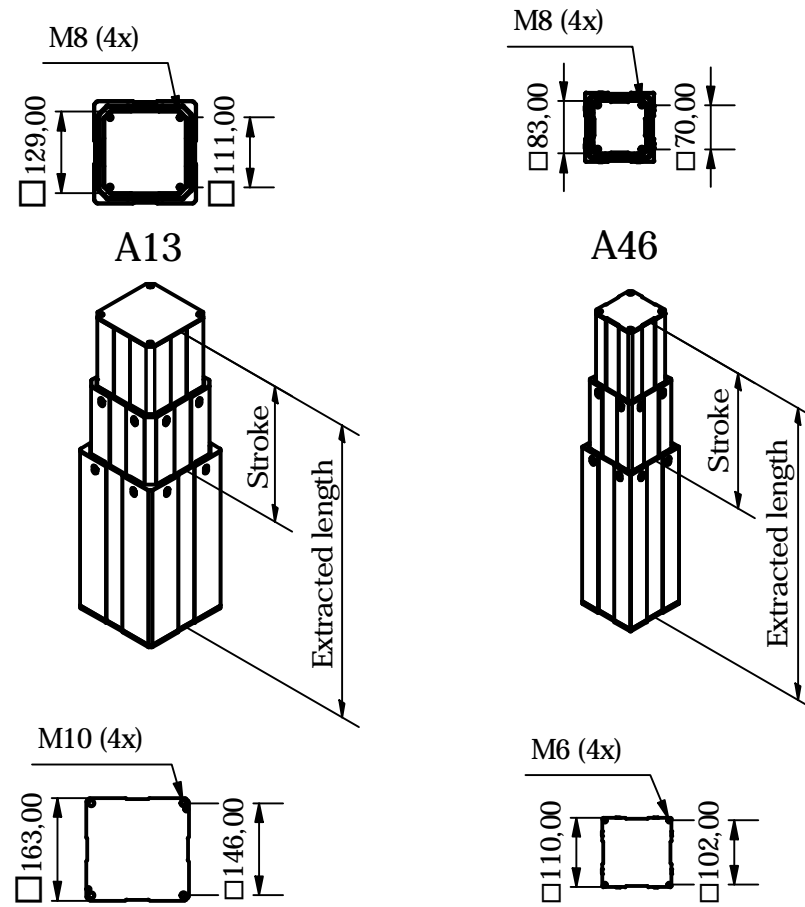

B-type
Available with 2- and 3-sections

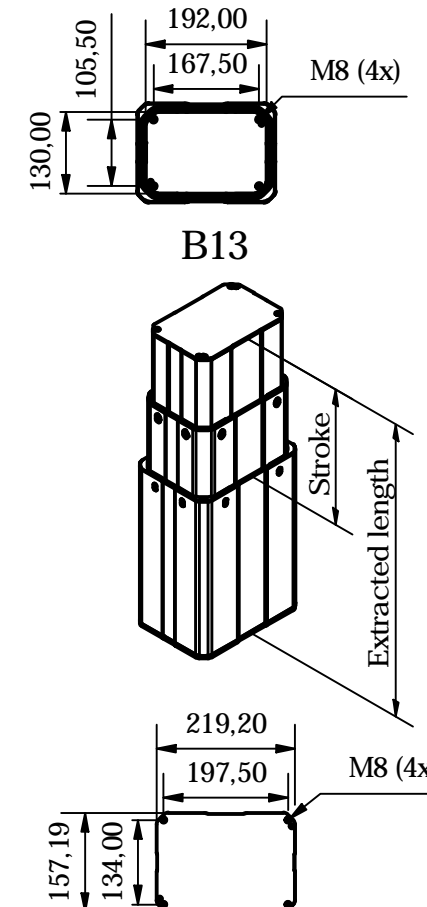

E-type
Available with 2-sections

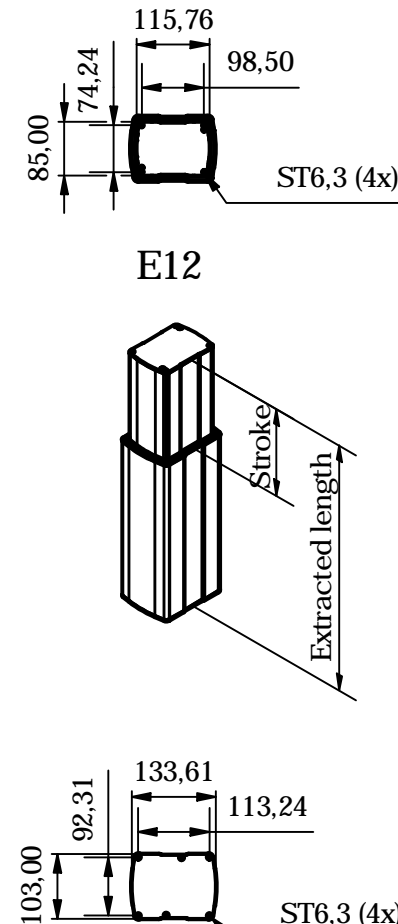

F-type
Available with 2- and 3-sections

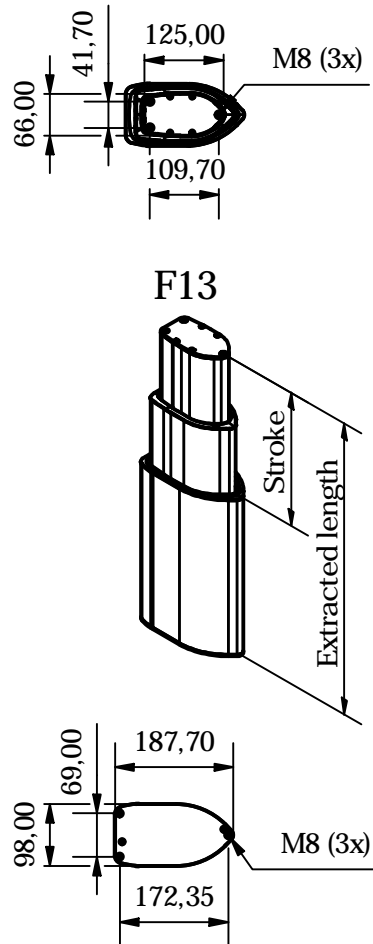

G-type
Available with 2- and 3-sections

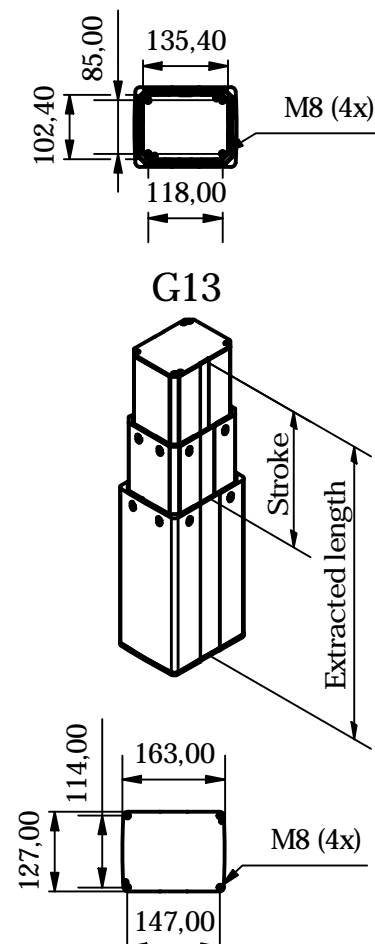

X-type
Available with 2- and 3-sections. Capable of Xtreme offset load

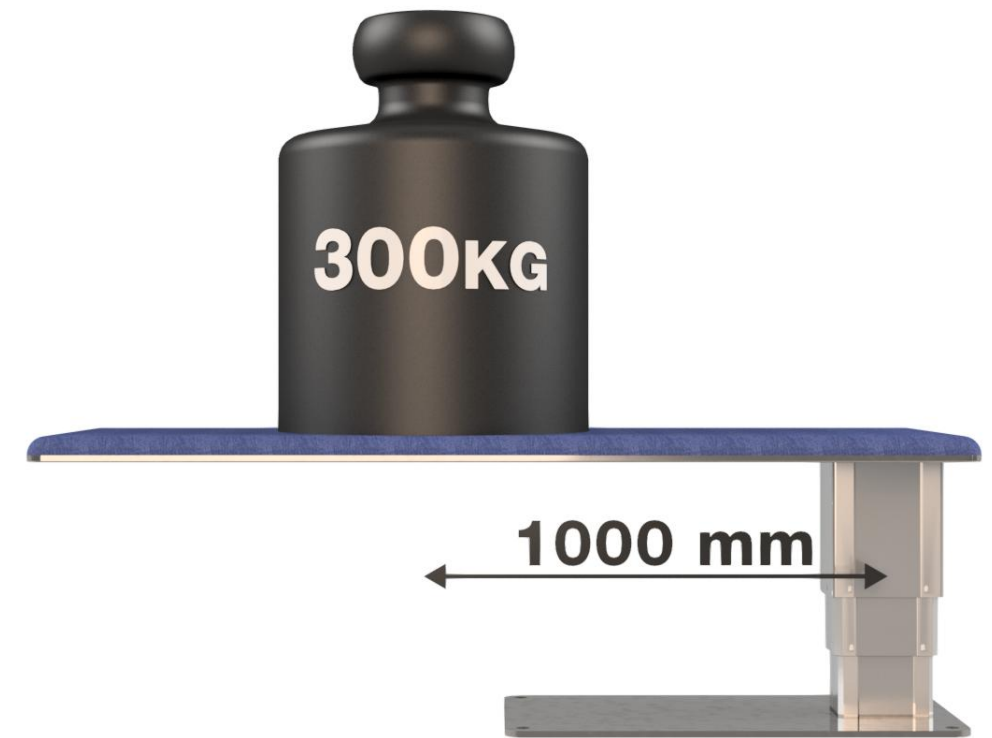
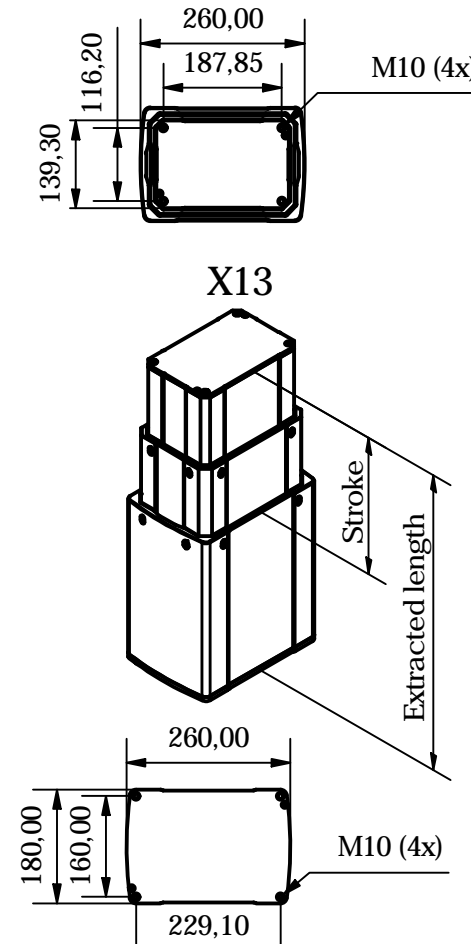

X2 Technology AB
www.x2technology.se
info@x2technology.se
Made in Sweden